

Name: Kenji Tsuruta Date: 8/31/2014 Event: ALPHA CUP  
 City: \_\_\_\_\_ State: \_\_\_\_\_ Track: Yoshino-Works  
 Track  Indoor  Tight  Smooth  Hard Packed  Blue Groove  Wet  Low Bite  High Bite  
 Conditions  Outdoor  Open  Rough  Loose/Loamy  Dry  Dusty  Med Bite  Other \_\_\_\_\_

**Front Suspension**

Toe: 2° Out  
 Ride Height: 28mm  
 Camber: -1°  
 Caster: 27°  
 Wheel Hex: Std  
 Sway Bar: 2.3mm  
 Piston/Oil: 1.3/30wt  
 Spring: Silver  
 Limiter/Droop: 103.5mm  
 Overall Shock Length: \_\_\_\_\_  
 Steering Ackerman: Long  
 Bump Steer: Up 3mm Spindle  
 Camber Link: 1  
 Shock Location: 1-Outside  
 Receiver Battery Type: Lipo

**Differentials**

Front:  Standard  Smart  
 Spring Wire Dia: \_\_\_\_\_  
 Qty of Springs: \_\_\_\_\_  
 Ramp Plate: \_\_\_\_\_  
 Grease: \_\_\_\_\_  
 Diff Fluid: 5000  
 Center:  Standard  Smart  
 Spring Wire Dia: \_\_\_\_\_  
 Qty of Springs: \_\_\_\_\_  
 Ramp Plate: \_\_\_\_\_  
 Grease: \_\_\_\_\_  
 Diff Fluid: 5000

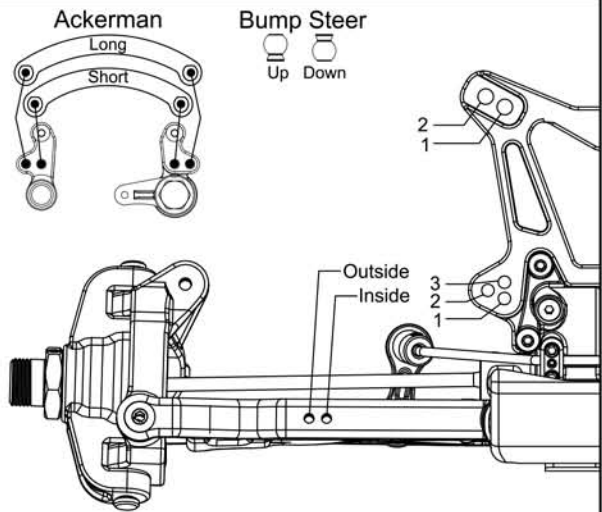

Notes: LOSA4440, LOSA99032  
TLR1557, TLR244021, TLR241005

**Rear Suspension**

Roll Center:  HRC  LRC  
 Toe: 3°  
 Anti-Squat: 3°  
 Ride Height: 30mm  
 Camber: -1.5°  
 Rear Hub Spacing: Mid  
 Wheel Hex: +1mm  
 Sway Bar: 2.5mm  
 Piston/Oil: 1.3x1.2/27.5wt  
 Spring: Silver  
 Limiter/Droop: 113mm  
 Overall Shock Length: \_\_\_\_\_  
 Camber Link: 1-B(4mm Down)  
 Shock Location: 2-Outside  
 Rear Diff Fluid: 3000

**Wing Setup**

Wing Type:  2.0  3.0  
 Wing Spacer:  .250  .500  
 Wicker Bill:  .250  .350

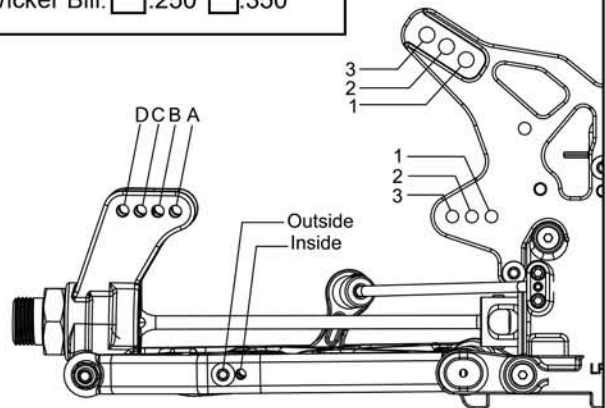

Notes: \_\_\_\_\_  
 \_\_\_\_\_  
 \_\_\_\_\_

**Engine**

Engine: 21-Ryan WS-B Fuel: COSMO 30%  
 Glow Plug: ALPHA T3 Head Clearance: 0.4mm  
 Pipe/Header: ALPHA 2107 Gearing: 48/13

**Clutch**



Clutch Shoes and Springs Info

2Alu w/Gold  
2Pra w/Green  
 \_\_\_\_\_  
 \_\_\_\_\_

**Tires**

	Type	Compound	Insert
Front:	<u>BLOCKADE</u>	<u>M4</u>	<u>PROLINE</u>
Rear:	<u>BLOCKADE</u>	<u>M4</u>	<u>PROLINE</u>
Notes:	_____		